

130R (B1)

RACCORDI IN GHISA MALLEABILE, TI RIDOTTA

THREADED FITTINGS MALLEABLE CAST IRON, REDUCING TEE



A
↑
paso-run

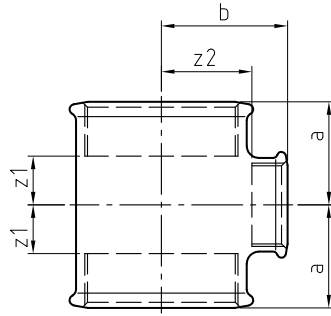

I (A=C>B)

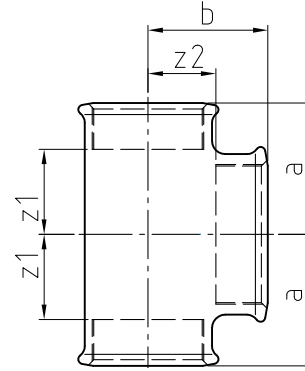

II (A=C<B)

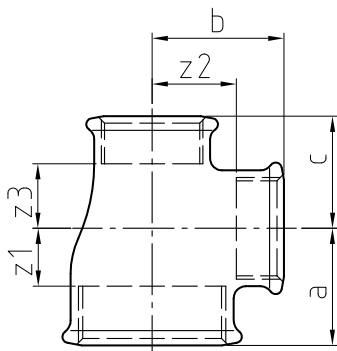

III (A>B e/and A>C;

B=C o/or B>C o/or B<C)

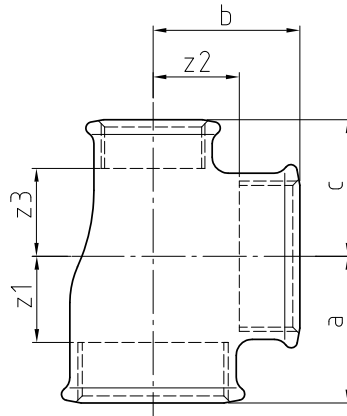

IV (A=B>C)

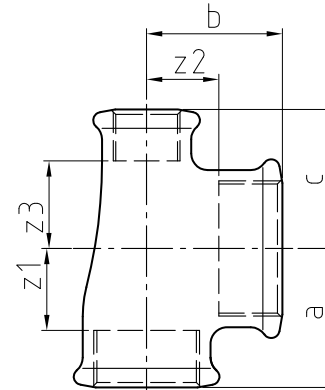

V (A>C; B>A; B>C)



INFORMAZIONI TECNICHE - TECHNICAL INFORMATION

Ø (AxBxC)	TIPO TYPE	COD.	DIMENSIONI - DIMENSIONS (mm)						Peso approx. Weight approx. (g)
			a	b	c	z1	z2	z3	
1/2" - 1/4" - 1/2"	I	13001/5313	24	24	-	11	14	-	82
1/2" - 1" - 1/2"	II	13001/5353	34	32	-	21	15	-	182
3/4" - 3/8" - 3/4"	I	13001/5424	28	28	-	13	18	-	139
3/4" - 1/2" - 1/2"	III	13001/5433	30	31	28	15	18	15	122
3/4" - 1/2" - 3/4"	I	13001/5434	30	31	-	15	18	-	148

Rev.2-04.23

1/5

130R (B1)

RACCORDI IN GHISA MALLEABILE, TI RIDOTTA

THREADED FITTINGS MALLEABLE CAST IRON, REDUCING TEE

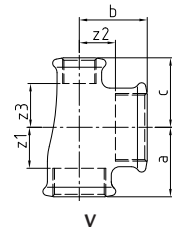
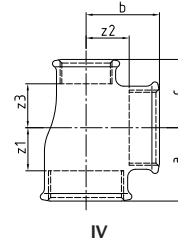
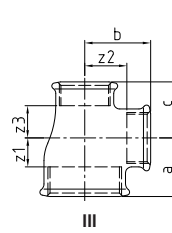
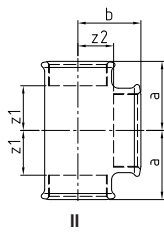
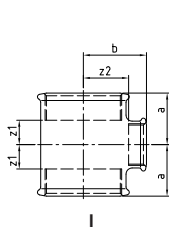

INFORMAZIONI TECNICHE - TECHNICAL INFORMATION

Ø (AxBxC)	TIPO TYPE	COD.	DIMENSIONI - DIMENSIONS (mm)						Peso approx. Weight approx. (g)
			a	b	c	z1	z2	z3	
3/4" - 3/4" - 1/2"	IV	13001/5443	33	33	31	18	18	18	188
	V	13001/5453	36	35	34	21	18	21	201
1" - 1/2" - 1"	I	13001/5535	32	34	-	15	21	-	196
1" - 3/4" - 3/4"	III	13001/5544	35	36	33	18	21	18	184
1" - 3/4" - 1"	I	13001/5545	35	36	-	18	21	-	232
1" - 1" - 1/2"	IV	13001/5553	38	38	34	21	21	21	246
1 1/4" - 1/2" - 1 1/4"	I	13001/5636	34	38	-	15	25	-	278
1 1/4" - 3/4" - 1 1/4"	I	13001/5646	36	41	-	17	26	-	355
1 1/4" - 1" - 1 1/4"	I	13001/5656	40	42	-	21	25	-	405

130R (B1)

RACCORDI IN GHISA MALLEABILE, TI RIDOTTA

THREADED FITTINGS MALLEABLE CAST IRON, REDUCING TEE

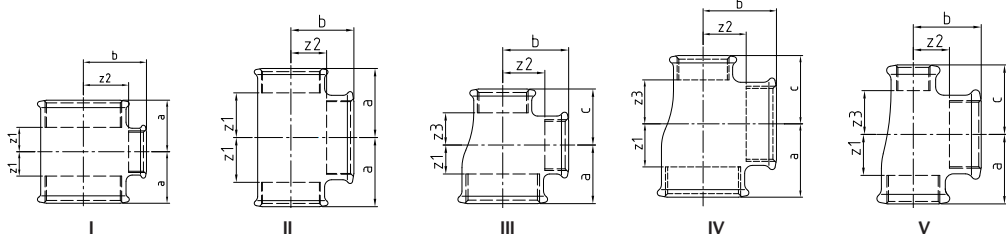

INFORMAZIONI TECNICHE - TECHNICAL INFORMATION

Ø (AxBxC)	TIPO TYPE	COD.	DIMENSIONI - DIMENSIONS (mm)						Peso appros. Weight aprox. (g)
			a	b	c	z1	z2	z3	
1 1/2" - 1/2" - 1 1/2"	I	13001/5737	36	42	-	17	29	-	362
1 1/2" - 3/4" - 1 1/2"	I	13001/5747	38	44	-	19	29	-	419
1 1/2" - 1" - 1 1/2"	I	13001/5757	42	46	-	23	29	-	472
1 1/2" - 1 1/2" - 1"	IV	13001/5775	50	50	46	31	31	29	457
2" - 1/2" - 2"	I	13001/5838	38	48	-	14	35	-	480
2" - 3/4" - 2"	I	13001/5848	40	50	-	16	35	-	592
2" - 1" - 2"	I	13001/5858	44	52	-	20	35	-	583

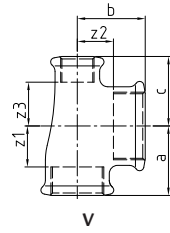
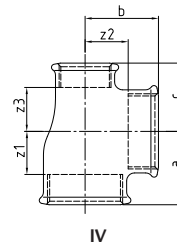
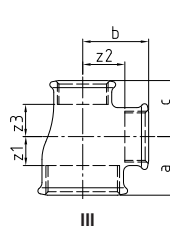
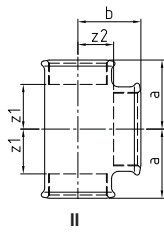
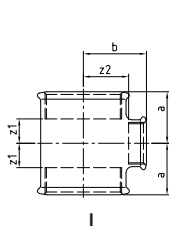

INFORMAZIONI TECNICHE - TECHNICAL INFORMATION

Ø (AxBxC)	TIPO TYPE	COD.	DIMENSIONI - DIMENSIONS (mm)						Peso appross. Weight approx. (g)
			a	b	c	z1	z2	z3	
2 1/2" - 2" - 2 1/2"	I	13001/5989	61	66	-	34	42	-	1.300
3" - 2" - 3"	I	13001/5A8A	64	73	-	34	49	-	1.687

CARATTERISTICHE FONDAMENTALI

- Raccordi filettati secondo UNI EN 10242 (simbolo di design A).
- Sottoposto a trattamento termico di decarburazione a 1060 °C.
- Materiale secondo a UNI EN 1562 (EN-GJMW-400-05):
 - * 0,2% Limite Elastico ($R_{p0,2}$): > 220 N/mm².
 - * Rottura Minima di Trazione: 400 N/mm².
 - * Allungamento minimo: 5 %.
 - * Durezza Brinell: < 220 HB.
- Zincato a caldo (min: spessore 70 µm ; massa gr/m²).
- Filettatura a tenuta stagna secondo UNI EN 10226-1 tipo R-Rp.
- Filettatura di serraggio (dadi di bloccaggio, controdadi e relativi giunti) secondo UNI EN ISO 228-1.
- Filettature: elementi di tenuta necessari (UNE-EN 751-1, 2 o 3 a seconda del fluido).
- Tenuta dell'unità (7 bar).

BASIC FEATURES

- Threaded pipe fitting according to EN 10242 (design symbol A).
- Material is annealing by heat treatment (decarburation at 1060 °C).
- Material conform to EN 1562 (EN-GJMW-400-05):
 - * 0,2% Proof Stress ($R_{p0,2}$): > 220 N/mm².
 - * Minimum Tensile Strength: 400 N/mm².
 - * Minimum Elongation: 5%.
 - * Brinell Hardness: < 220 HB.
- Hot dip Galvanising (min: layer thickness 70 µm ; coating mass 500 gr/m²).
- Jointing thread acc. EN-10226-1 type R-Rp.
- Fastening thread (backnuts, union nuts and their matings) acc. EN ISO 228-1.
- Threads: needed sealing assistance (EN 751-1, 2 or 3 acc. fluid).
- Unitary leak tightness (7 bar).



CONDIZIONI DI LAVORO AMMESSE

- Idoneo al trasporto di fluidi entro i seguenti limiti P-T:
 - da -20 a 120 °C: 25 bar (2,5 MPa)
 - da 120 a 300 °C: 25 a 20 bar (2,0 MPa)
 - 300 °C: 20 bar (2,0 MPa)
- Gas non esplosivi (da DN 10 a DN 100):
 - da 0 a 85 °C *: 25 bar (2,5 MPa)
- Gas combustibili e esplosivi (DN 10 a DN 50):
 - max. 5 bar (0,5 MPa) * o secondo obbligo di legge

* Sotto la responsabilità del Project Management, tutte le installazioni devono essere conformi ai valori P-T stabiliti tecnicamente e legalmente.

CONDIZIONI DI LAVORO AMMESSE

- Adatto per tubi in acciaio UNI EN 10255 (da 1/8 a 6 pollici).
- Impianti di Riscaldamento, Climatizzazione e Ventilazione.
- Impianti sanitari, acqua calda e fredda.
- Installazioni di ACQUA POTABILE FREDDA.
- Impianti antincendio.
- Impianti Aria Compressa, Industriale, Automotive e Macchinari.
- Impianti di irrigazione.

Osservazioni:

Data la complessità, la varietà e l'elevato numero di specifiche particolari di ciascuna installazione, unitamente all'esistenza di vari fattori che possono influenzare le condizioni di lavoro e la natura del prodotto, è responsabilità dell'utente finale eseguire le prove necessarie per garantire il corretto funzionamento del prodotto in ogni specifica applicazione.

L'installazione del prodotto deve essere eseguita e mantenuta secondo codici di buona pratica e/o norme vigenti.

VANTAGGI

- Prestazioni meccaniche superiori.
- Elevata resistenza alla corrosione.
- Elevata resistenza al fuoco.
- Elevata durata comprovata.
- Versatilità di alta gamma.
- Valido per l'acqua destinata al consumo umano.
- Numerose certificazioni di prodotto europee.
- Prodotto riciclabile al 100%.

PERMISSIBLE WORKING CONDITIONS

- Appropriate for the transmission of fluids up to the limit P-T specified:
 - 20 up to 120 °C: 25 bar (2,5 MPa)
 - since 120 up to 300 °C: 25 to 20 bar (2,0 MPa)
 - 300 °C: 20 bar (2,0 MPa)
- Non explosive gases (DN 10 to DN 100):
 - since 0 up to 85 °C *: 25 bar (2,5 MPa)
- Fuel and gases explosives (DN 10 to DN 50):
 - max. 5 bar (0,5 MPa) * or legal requirement

* Under the Engineering Project Management liability, all installations has to meet the P-T values technical and legally established.

GENERAL APPLICATIONS

- Suitable for steel pipes acc. EN 10255 (1/8 to 6 inches).
- Heating/cooling systems, Air conditioning and Ventilation.
- Sanitary water systems, Cold and hot water.
- Installations of Cold WATER for HUMAN consumption.
- Fire Fighting Installations.
- Pressured air pipe works, Industrial Installations, Automotive Industry and Machinery.
- Irrigation systems.

Remarks:

Due to the complexity, variety and large number of particular specifications for each installation, along with the existence of diverse factors which can affect the working conditions and nature of the product, it is the responsibility of the end-user to carry out the necessary tests to ensure the proper functioning of the product in any specific application.

Product installation must be carried out and maintained following the good practice codes and/or updated technical standards.

ADVANTAGES

- High mechanical performances.
- High resistance to corrosion.
- High resistance to fire.
- Demonstrated high durability.
- Big assortment of fitting, wide range.
- Suitable for human water consumption.
- Numerous European product certifications.
- Product 100% Recyclable.

Nota: A causa del costante sviluppo dei nostri prodotti, i dati forniti possono essere modificati senza preavviso.

Note: Due to the continuous development of our products, specifications may be changed without notification at any time.