

Codice Dianflex:320-1110S-05044

A-A (1 : 1.5)

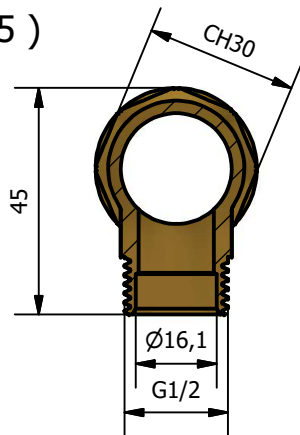

B-B (1 : 1.5)

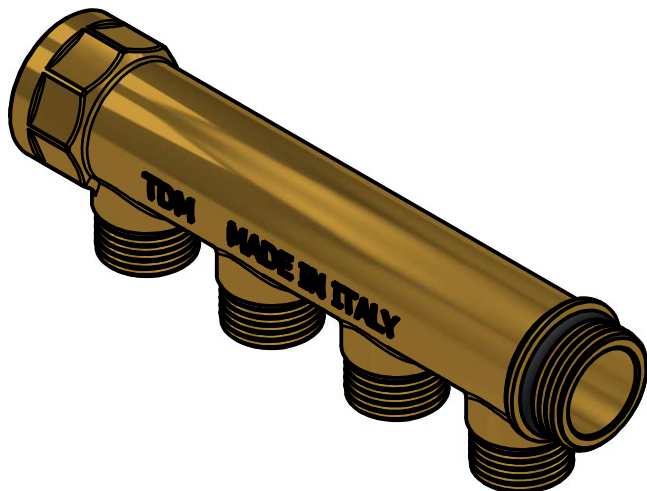
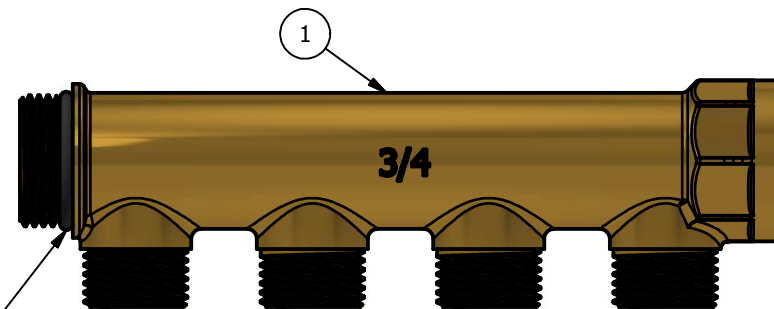
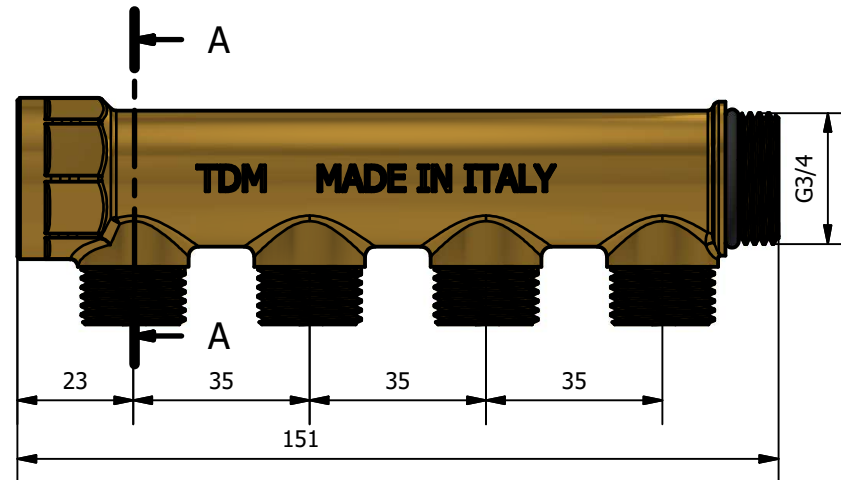
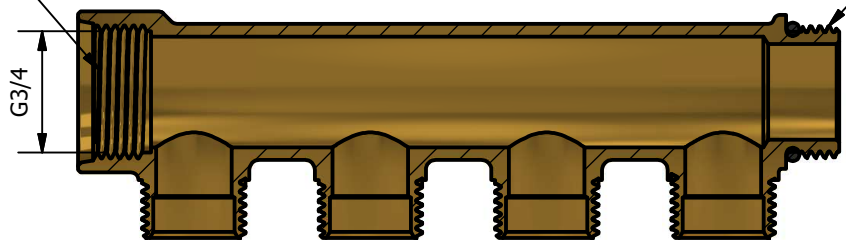

N°	DESCRIPTION	MATERIAL		
1	BODY	CW617N EN12165		
2	O-RING	EPDM-PEROX	MIN-MAX WORKING TEMPERATURE	0°c +110°c
3	THREAD FEMALE-MALE SYNCHRONIZED		MAX PRESSURE	10 BAR
00	Prima emissione		Delaini M.	05/03/2025
Rev.	Nota Revisione		Approvatore	Data Approvazione
Toll Gen:	JS13	Stato sup.:	Giallo Sabbiato	
Filetto:	ISO 228	Note tecniche:		
Peso lavorato:	Peso grezzo:	N° stampo:	Codice: 1110S 3412 4 scheda	
Materiale:			Descrizione: Brass linear manifold yellow synchronized	
		Disegnatore: Delaini P.	Data:05/03/2025	