

Codice Dianflex: 320-1110-05043

A-A (1 : 1.2)

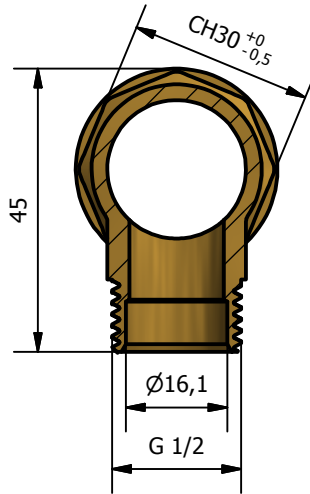

B-B (1 : 1.2)

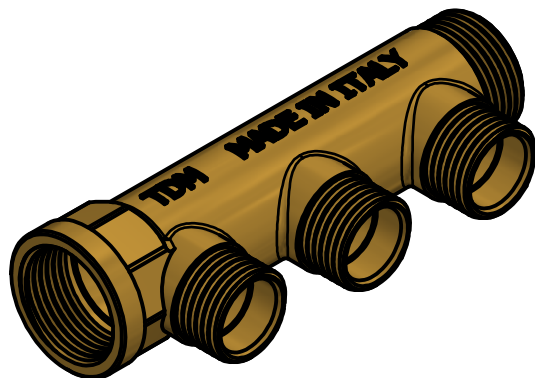
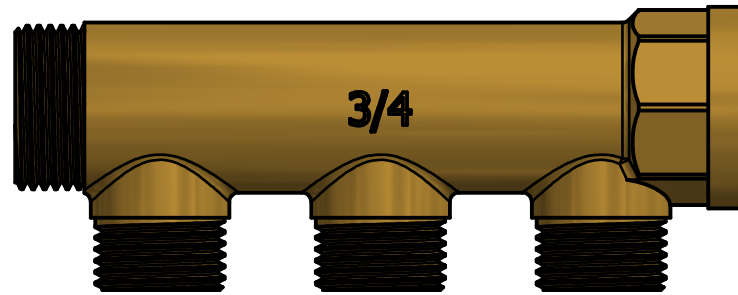
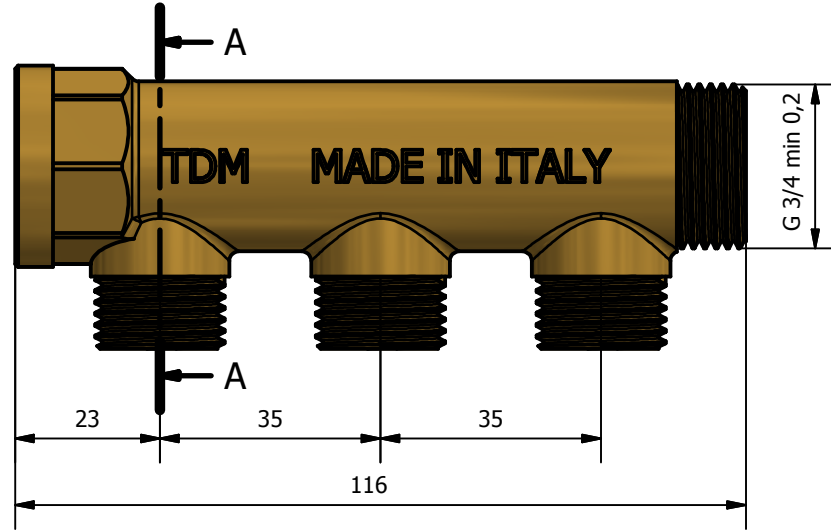
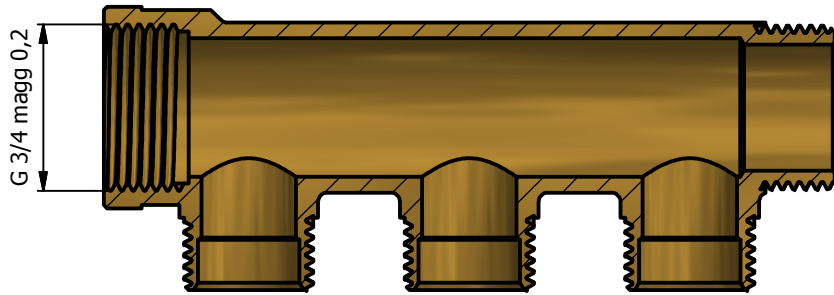

MIN-MAX WORKING TEMPERATURE	0°C +110°C
MAX PRESSURE	10 BAR

00	Prima emissione		Delaini M.	20/02/2012
Rev.	Nota Revisione		Approvatore	Data Approvazione
Toll Gen:	JS14	Stato sup.:	Giallo Sabbiato	
Filetto:	ISO 228	Note tecniche:		
Peso lavorato:	Peso grezzo:	N° stampo:	Descrizione: Brass linear manifolds yellow 3/4x1/2 3 way	
Materiale:	CW 617N EN12165		Disegnatore: Delaini P.	Data: 20/02/2012

Codice: 1110 3412 3 Scheda

