

Codice Dianflex: 320-1110-06042

A-A (1 : 1.5)

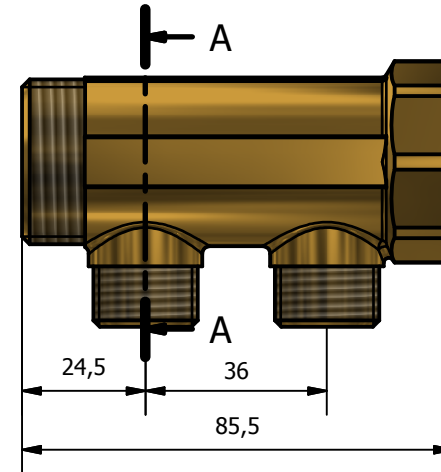

B-B (1 : 1.5)

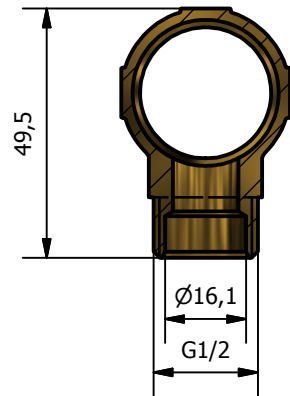
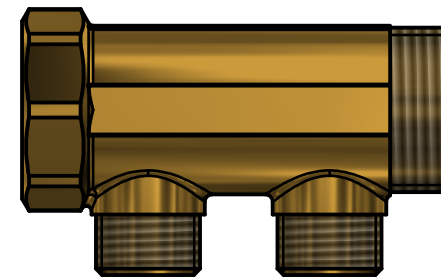
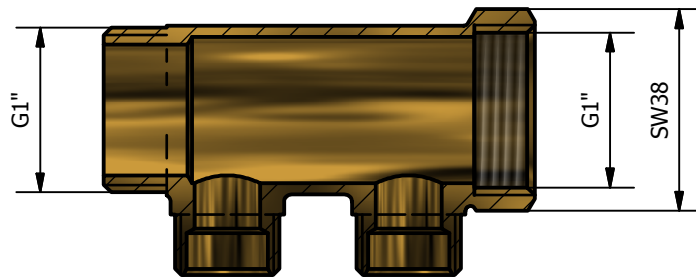

MIN-MAX WORKING TEMPERATURE	0°c +110°c
MAX PRESSURE	10 BAR

00	Prima emissione		Delaini M.	20/02/2012
Rev.	Nota Revisione		Approvatore	Data Approvazione
Toll Gen:	JS14	Stato sup.:	Giallo Sabbiato	
Filetto:	ISO 228	Note tecniche:		
Peso lavorato:	Peso grezzo:	N° stampo:	Codice: 1110 0112 2 scheda	
Materiale: CW 617N EN12165			Disegnatore: Delaini P.	Data: 20/02/2012
			Descrizione: Brass linear manifolds yellow 1"x1/2 2 way	